



AE1300HEU Owner's Manual



HYDRO AERATOR Owner's Manual

AE1300HEU

Beginning Serial #: 020216001

Accessories

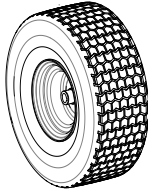
FOAM TIRES
Reduces chance for flat tires and also adds weight to the machine

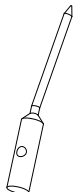
P/N 362601

SOLID SPIKE TINE
Complete set of spike tines for the AE's arms.

P/N 360611

TINE KIT
Individual coring tine for replacement of worn or broken tines.

P/N 360100

Original Instructions

IMPORTANT- READ CAREFULLY BEFORE USE AND KEEP FOR FUTURE REFERENCE.



AE1300HEU Owner's Manual

CONTENTS

SPECIFICATIONS AND SOUND/VIBRATION	3
INSTRUCTION LABELS	4
PACKING CHECKLIST & ASSEMBLY	5
OPERATION	6
MAINTENANCE	7-9
TROUBLESHOOTING	10
ILLUSTRATED PARTS & PARTS LIST	11-23
DECLARATION OF CONFORMITY	24-26



AE1300HEU Owner's Manual

SPECIFICATIONS

AE1300HEU

Engine: HP	13 (9.7 kW)
Engine: Model	GX390UTQA2
Engine: Type	Honda OHV
Engine: Fuel Capacity	6.4qt. (6.1 L)
Engine: Oil Capacity	1.16 qt. (1.1 L)
Total Unit Weight:	529# (240 Kg)
Max. operating slope	15°
Sound test in accordance with 2000/14/EC	103dB(a)
Sound at operators ear	83dB(a)
Vibration at operator position	0.7g (6.67 m/s ²)

SOUND



103

SOUND LEVEL 83 dB(a) at Operators Position

Sound tests were conducted in accordance with 2000/14/EC, and were performed on 1/16/15 under the conditions listed below.  Sound power level listed is the highest value for any model covered in this manual. Please refer to serial plate on the unit for the sound power level for your model.

General Conditions:	Sunny
Temperature:	53°F (12°C)
Wind Speed:	16 mph (26 kph)
Wind Direction:	South Southwest
Humidity:	40%
Barometric Pressure:	30Hg (102 kpa)

VIBRATION DATA

VIBRATION LEVEL .7g (6.67 m/s²)

Vibration levels at the operator's handles were measured in the vertical, lateral and longitudinal directions using calibrated vibration test equipment. Tests were performed on 1/16/15 under the conditions listed below.

General Conditions:	Sunny
Temperature:	53°F (12°C)
Wind Speed:	16 mph (26 kph)
Wind Direction:	South Southwest
Humidity:	40%
Barometric Pressure:	30Hg (102 kpa)



AE1300HEU Owner's Manual

INSTRUCTION LABELS

The labels shown below were installed on your BILLY GOAT® Aerator. If any labels are damaged or missing, replace them before operating this equipment. Part numbers from the Illustrated Parts List are provided for convenience in ordering replacement labels. The correct position for each label may be determined by referring to the part numbers shown.



LABEL WARNING GUARDS
P/N 900327



LABEL EXPLOSIVE FUEL
P/N 400268



LABEL HIGH PRESSURE
P/N 362506



LABEL DUMP VALVE
P/N 501504



LABEL HYDRAULIC INST
P/N 362507



LABEL WARNING GUARDS
P/N 400424



LABEL HOT SURFACE
P/N 100258



LABEL INSTRUCTIONS AE
P/N 362501



LABEL TIE DOWN
P/N 352510

ENGINE LABELS

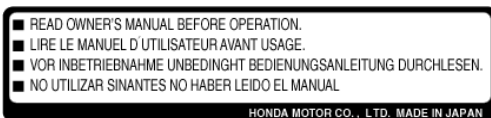

Part No 362511

HONDA



4

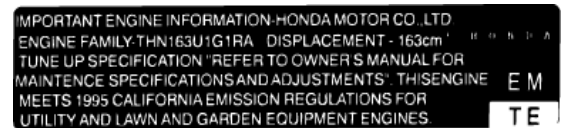

Form No F020216B



AE1300HEU Owner's Manual

PACKING CHECKLIST

Your Billy Goat is shipped from the factory in one carton, completely assembled.



READ all safety instructions before assembling unit.
TAKE CAUTION when removing the unit from the box.



PUT OIL IN ENGINE BEFORE STARTING

PARTS BAG & LITERATURE ASSY

Warranty card P/N- 400972, Owner's Manual P/N-362511, General Safety and Warnings Manual Renovation-100295, Declaration of Conformity P/N-362513.

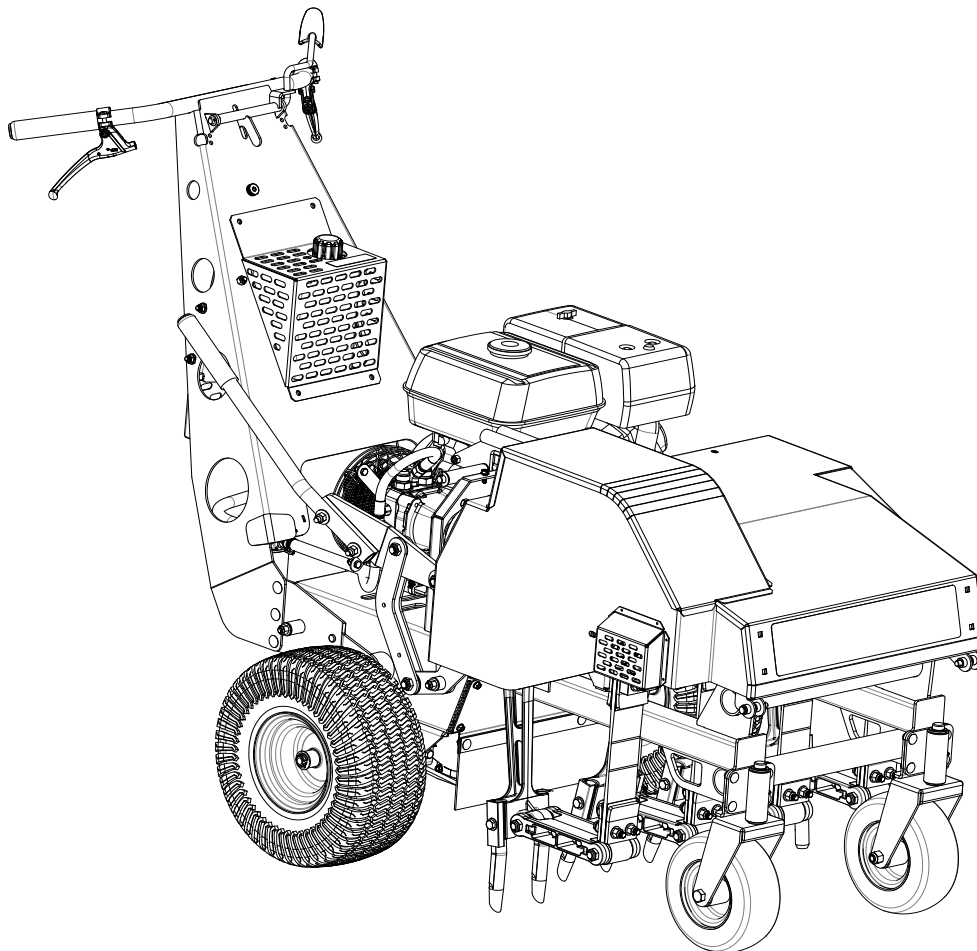

Boxing Parts Checklist

Owner's Manual
AE1300HEU 362511

Engine Manual Per Model

Honda 13 HP

ASSEMBLY

1. **CHECK** engine oil level and fill to proper level.
2. **CONNECT** spark plug wire. Set the engine stop switch to the **ON** position. You will use the stop switch on the handle during operation.



AE1300HEU Owner's Manual

CONTROLS

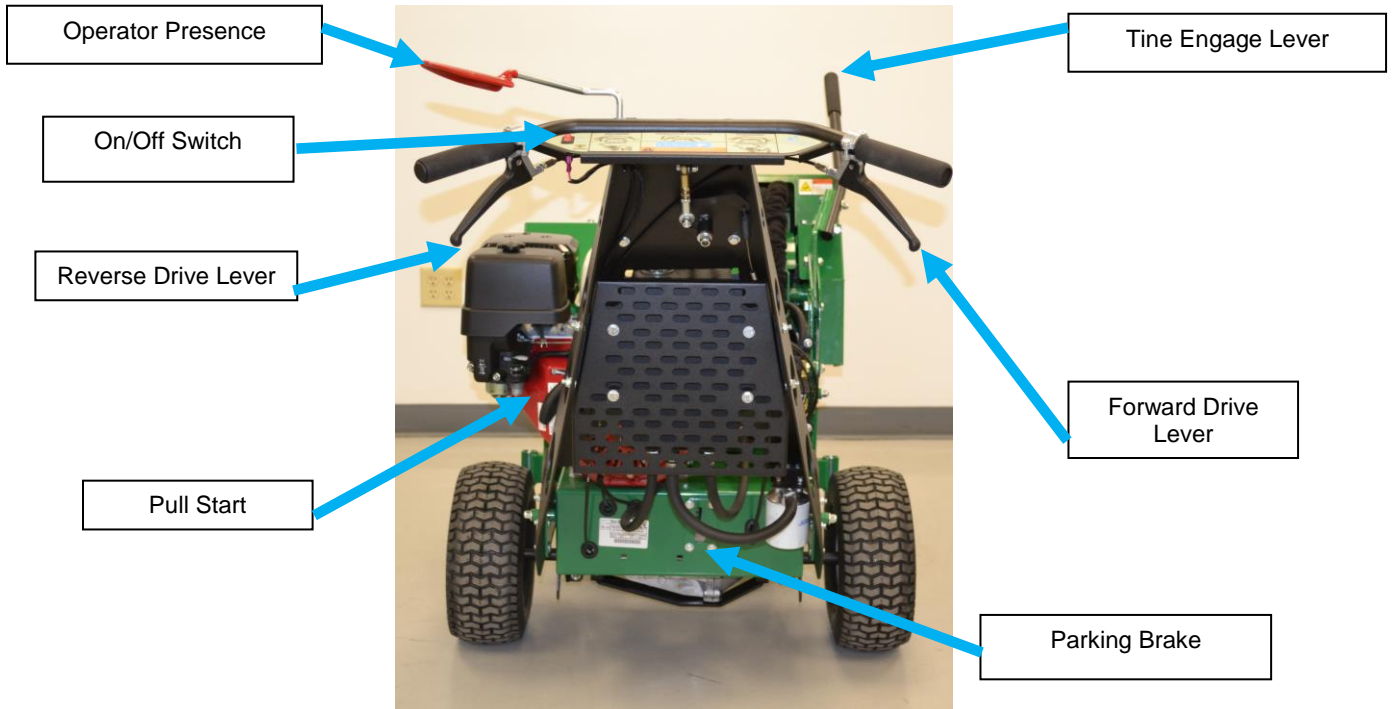

I 0 	REVERSE 	OPERATOR PRESENCE 	FORWARD 	 FOR BEST RESULTS SOIL SHOULD BE DAMP WHEN AERATING
	AERATE 	 WARNING: DO NOT OPERATE WITHOUT GUARDS IN PLACE	TRANSPORT 	



AE1300HEU Owner's Manual

OPERATION

AERATING OPERATION

NOTE: NEVER PARK THIS UNIT ON A SLOPE OF ANY KIND. Always keep tines in the up position when parking the unit.

TINES RAISING/LOWERING: The tines are raised or lowered into the ground by operating the tine engagement lever on the right of the machine. When engaging the ground, be sure that lever cams over and locks into place. Tine penetration is very dependent on surface preparation. When removing the tines from the engagement position, make sure the lever fully cams over into the forward position for transport. READ the entire operation section before aerating.

ENGAGE TINES: With the aerator in the work area, lower the tines into the ground with the tine lowering lever and engage the tine lever on the left hand side of the handle.

SPEED: It is recommended for proper aerating performance that the engine be operated at maximum RPM. Control ground speed using the forward/reverse drive levers. Speed is proportional to the extent the levers are actuated.

AERATE: With the tines engaged, engage either the forward or reverse drive lever for the desired direction of travel. Note: Core spacing on this machine is determined by speed. The faster you travel the further the spacing between cores pulled and vice versa. **NOTE: The hydraulic system may seem sluggish until the oil reaches a normal operating temperature.**

PARKING BRAKE: To set the parking brake, push the lever located on the rear of the engine base down and to the right so that it catches. To release the brake, simply push the lever back down and slide it to the left. When the lever is to the right, the parking brake is on. When the lever is to the left the parking brake is off.

TRANSPORT: Be sure to lift the tine engagement lever (tines out of the ground) before transporting away from the work area.

LIFTING AND TIE DOWN: DO NOT Lift this unit. Tie down points are located on the frame with labels. Always secure the unit at tie down points before transporting to job site.

*****TIPS*****

MOW

Mow the lawn to its normal cut height.

WATER

For the best performance and maximum tine penetration the lawn should be thoroughly watered the day before aeration.

INSPECT

Check the lawn before beginning work. Remove all rocks, wire, string, or other objects that can present a hazard during work prior to starting.

IDENTIFY

Mark all fixed objects to be avoided during work, such as sprinkler heads, water valves, buried cables, or clothes line anchors, etc.

SLOPES

Do not operate the aerator on steep slopes. Use extreme caution when operating on any sloped surface. For lesser sloped areas operate the unit, traversing up and down at a 45 degree angle to the slope rather than straight across. Extended operation on steep slopes can cause engine damage. **NOTE: DO NOT** release the operators clutch bail when operating on a slope. This will allow the unit to free wheel and allow the unit to roll down the slope. **NOTE:** Honda engines are equipped with a low oil sensor to prevent engine damage. When it senses a low oil condition (i.e. unit is operating or sitting on a steep slope) the engine shuts down. The maximum operating slope for the engine is 20°. The low oil condition must be corrected before the engine can be restarted. See the engine owner's manual for more information.



AE1300HEU Owner's Manual

MAINTENANCE

PERIODIC MAINTENANCE

Periodic maintenance should be performed at the following intervals:

Maintenance Operation	Every Use (daily)	Every 10 hrs	Every 25 hrs	Every 50 Hours
Inspect for worn or damaged parts	●			
Check for loose parts	●			
Check engine oil	●			
Thoroughly clean all debris from unit and tine arms	●			
Oil chains (see lubrication)		●		
Lubricate speed control cables and linkage		●		
Lubricate clutch control cable and linkage		●		
Check Hydraulic oil			●	
Grease front caster assemblies			●	
Inspect belt for wear				●
Check rear tire pressure				●

FOR INFORMATION REGARDING SERVICE INTERVALS FOR ENGINE, REFER TO SUPPLIED ENGINE MANUAL

ENGINE MUST BE LEVEL WHEN CHECKING OR FILLING OIL

SERVICING HYDRAULIC SYSTEM

NOTE: DO NOT SERVICE HYDRAULIC SYSTEM WHEN IT IS HOT.

WARNING: Due to the dangerous potential of fluid injection, you should always use a piece of paper to check for hydraulic leaks rather than using your fingers.



READ all safety instructions before servicing unit.



WARNING:

DISCONNECT spark plug wire before servicing unit.

1. To check the hydraulic oil level, twist the breather cap on the oil tank counter-clockwise ¼ turn and remove. When looking inside the filler hole, you should fill the tank so that you can just see oil start to cover the bottom of the internal strainer. Use 20W-50 engine oil for normal operating temperatures and for colder climates switch to 15W-40. An excellent choice for colder climates is Mobil 10W-40 Synthetic oil. Over-filling the tank will result in excess oil sloshing out of the breather during operation.
2. To change the oil filter it is advisable to clamp the hose from the tank prior to loosening the filter in order to prevent excessive spilling of hydraulic oil.
3. Remove filter by un-screwing counter-clockwise from filter base.
4. When replacing filter (Billy goat P/N 362396), it is recommended to spread a thin coat of oil on the rubber gasket of the filter prior to re-installing.
5. After the rubber gasket seats, turn an additional 2/3 turn.

See page 22 for Hydraulic Schematic.



AE1300HEU Owner's Manual

NOTE: Items in () can be referenced in the Parts Illustrations and Parts Lists on pages 12-23.

INDIVIDUAL TINE REPLACEMENT (See page 14 and 15 for Parts Illustration and Parts list)

1. While it is possible to replace only one tine at a time, it is recommended to replace tines in pairs on a tining arm.
2. To replace tines, simply remove the 3/8" bolt that passes through the tining arm assembly. In this way, the tines can be removed from the arm by sliding outward from the tining arm.
3. Remove the worn or broken tines from the assembly.
4. Inspect the bolt for wear, straightness, or thread damage. If the bolt is damaged, it should be replaced. This bolt is a Grade 8 fastener. Replacing with a weaker bolt is not recommended.
5. To re-install, place a washer on the tine holder and then a tine onto the bolt. Now install these onto the tining arm with the open side of the tine facing the rear of the machine. Once the bolt is through the tining arm, place another tine on the bolt, then a tine holder. Finally, install a washer and nylon inserted lock nut. Tighten the assembly. Be careful not to over tighten which will bend the tine holders.

NOTE: Tines are a normal wear item and should be inspected regularly for signs of wear or damage.

BELT AND CHAIN TENSION ADJUSTMENT



READ all safety instructions before servicing unit.



WARNING:

DISCONNECT spark plug wire before servicing unit.

ADJUSTING BELT TENSION (See page 12 and 13 for Parts Illustration and Parts list)

1. Proper belt tension needs to be maintained to prevent slippage during operation. When bail is fully actuated the length of the coiled portion of the clutch cable spring should be 1.75".
2. If the clutch cable spring needs adjustment, loosen the jam nuts holding the cable on the handle assembly and adjust the cable either in or out to shorten or lengthen the spring.
3. Once proper adjustment is reached, tighten the jam nuts.
4. Once adjustment is made, re-install spark plug wire and test adjustment. The machine hydraulic pump and transaxle should dis-engage when the bail is released. There should be no evidence of belt slippage (reduced ground speed or slow tine RPM) when operating the machine with bail engaged.

NOTE: Never release the clutch on a slope. The unit is heavy and will free wheel downhill.

NOTE: A worn belt will not allow for proper adjustment and must be replaced.

ADJUSTING CHAIN TENSION (See page 14 and 15 for Parts Illustration and Parts list)

1. Remove the hood (item 4) by removing the seven bolts, washers, and lock washers. (items 111,119,128), that secure it to the tining frame.
2. Locate the bolt (item 31, 33) and nut (item 80) that hold each chain idler sprocket to the tining frame of the unit. One idler sprocket sets tension on the left tine drive chain and one sets tension on the right tine drive chain.
3. Loosen the bolt and nut and slide the idler sprocket (item 29) in the desired direction.

INCREASED TENSION: Slide the sprocket up.

DECREASED TENSION: Slide the idler sprocket down.

4. Tighten the bolt and nut to secure the sprocket in place.
5. Replace the hood and reinstall the seven bolts, washers, and lock washers that secure it in place.

NOTE: Over tensioning the chain will cause premature chain and sprocket wear. **DO NOT OVER TENSION THE CHAIN.** A properly tensioned chain will have slack of 3/8"-1/2" when moved by hand.



AE1300HEU Owner's Manual

DRIVE BELT REPLACEMENT (See page 12 and 13 for Parts Illustration and Parts list)



READ all safety instructions before servicing unit.



WARNING:

DISCONNECT spark plug wire before servicing unit.

1. Disconnect spark plug wire.
2. Loosen four screws (item 112) holding belt cover (item 10) and remove the cover.
3. Examine condition of belt. Look for cracks, splits, delamination or damage to outer covering. Any of these things might warrant replacement.
4. If the idler is not providing enough tension inspect the clutch cable spring (item 231) underneath the handle. This spring body should stretch to a length of 1.75" when the operator presence handle is actuated. If not enough tension is being put on the spring this could mean a stretched belt, but most likely the cable needs adjusted. Simply loosen the jam nuts holding the cable on the handle assembly and adjust the cable either in or out to shorten or lengthen the spring. Retighten nuts and check spring stretch.
5. Replace belt cover (item 10) and secure with screws removed earlier.
6. Reconnect spark plug wire.
7. Check belt tension by operating unit under conditions that caused belt slippage. If belt continues to slip it may require replacement before operation may continue.

CHAIN REPLACEMENT (See page 14 and 15 for Parts Illustration and Parts list)

1. Remove the hood (item 4) by removing the seven bolts, washers, and lock washers. (items 111,119,128), that secure it to the timing frame.
2. Locate the bolt (items 31, 33) and nut (item 80) that hold each chain idler sprocket to the timing frame of the unit. One idler sprocket sets tension on the left tine drive chain and one sets tension on the right tine drive chain.
3. Loosen the bolt and nut and slide the idler sprocket (item 29) to the bottom of the slot in the bracket.
4. Locate the master link in the chain and remove.
5. When installing new chain make sure that the inner crank arm is lined up with the inner crank arm of the opposite side. In operation, the two inner timing arms move together and the two outer timing arms move together. Any other timing of the arms will result in unsatisfactory performance of the machine.
6. Once new chain is installed, replace the hood and reinstall the seven bolts, washers, and lock washers that secure it in place.

NOTE: Over tensioning the chain will cause premature chain and sprocket wear. **DO NOT OVER TENSION THE CHAIN.** A properly tensioned chain will have slack of 3/8"-1/2" when moved by hand.

CHAIN LUBRICATION (See page 14 and 15 for Parts Illustration and Parts list)

1. Remove the top guard by removing the four nuts, two on each side that secures it to the frame.
2. Apply a light coat of No. 30 Oil or a penetrating chain lubricant to keep the chain clean and in good running order.
3. Replace the guard and reinstall the four screws that secure it in place.

NOTE: If machine is cleaned with a pressure washer the chains should be lubricated after each cleaning.



AE1300HEU Owner's Manual

TROUBLESHOOTING

Problem	Possible Cause	Solution
Engine will not start	Stop switch off (Honda only). Throttle in off position. Engine not in full choke position. Out of gasoline. Bad or old gasoline. Spark plug wire disconnected. Dirty air cleaner. Engine oil level too low (Honda only).	Check stop switches, throttle, choke position and gasoline. Connect spark plug wire. Clean or replace air cleaner. Or contact a qualified service person. Check and fill engine oil.
Abnormal vibration	Damaged or missing tines. Loose handle bolts. Loose engine bolts.	Stop work immediately. Replace any damaged or missing tines. Tighten all loose bolts and nuts.
Engine stalls or labors when aerating	Working on too steep of a slope. Not enough oil in the engine. Hydraulic oil not up to operating temperature	Work at 45 degrees to the slope moving up and down instead of across. Check and add engine oil. Allow for hydraulic oil to reach operating temperature
Engine is locked, will not pull over	Debris locked against reel, or drive pulleys. Engine problem.	Pull spark plug wire and remove debris. Contact an engine servicing dealer for engine problems.
Unit does not move when clutch is engaged.	Belt drive out of adjustment. Worn drive belt. Loose or damaged chain or sprockets. Loose or damaged pulleys. Damaged or broken clutch cable. Transmission bypass set in free-wheel	See maintenance on pg. 8 of this manual. Contact a qualified servicing dealer. Set transmission bypass in drive

When servicing engine refer to specific manufacturer's engine owner's manual. All engine warranty is covered by the specific engine manufacturer. If your engine requires warranty or other repair work contact your local servicing engine dealer. When contacting a dealer for service it is a good idea to have your engine model number available for reference (See table page 3). If you cannot locate a servicing dealer in your area you can contact the manufacturer's national service organization.

To reach:

American Honda: 800-426-7701

WARRANTY CLAIM PROCEDURE

Should a BILLY GOAT[®] machine fail due to a defect in material and/or workmanship, the owner should make a warranty claim as follows:

- The machine must be taken to the dealer from whom it was purchased or to an authorized Servicing BILLY GOAT Dealer.
- The owner must present the remaining half of the Warranty Registration Card, or, if this is not available, the invoice or receipt.
- The Warranty Claim will be completed by the authorized BILLY GOAT Dealer and submitted to their respective BILLY GOAT Distributor for their territory Attention: Service Manager. Any parts replaced under warranty must be tagged and retained for 90 days. The model number and serial number of the unit must be stated in the Warranty Claim.
- The distributor service manager will sign off on the claim and submit it to BILLY GOAT for consideration.
- The Technical Service Department at BILLY GOAT will study the claim and may request parts to be returned for examination. BILLY GOAT will notify their conclusions to the distributor service manager from whom the claim was received.
- The decision by the Technical Service Department at BILLY GOAT to approve or reject a Warranty Claim is final and binding.

Make sure that the product is registered with Billy Goat. For online product registration go to www.billygoat.com



AE1300HEU Owner's Manual

AE1300HEU PARTS DRAWING ENGINE

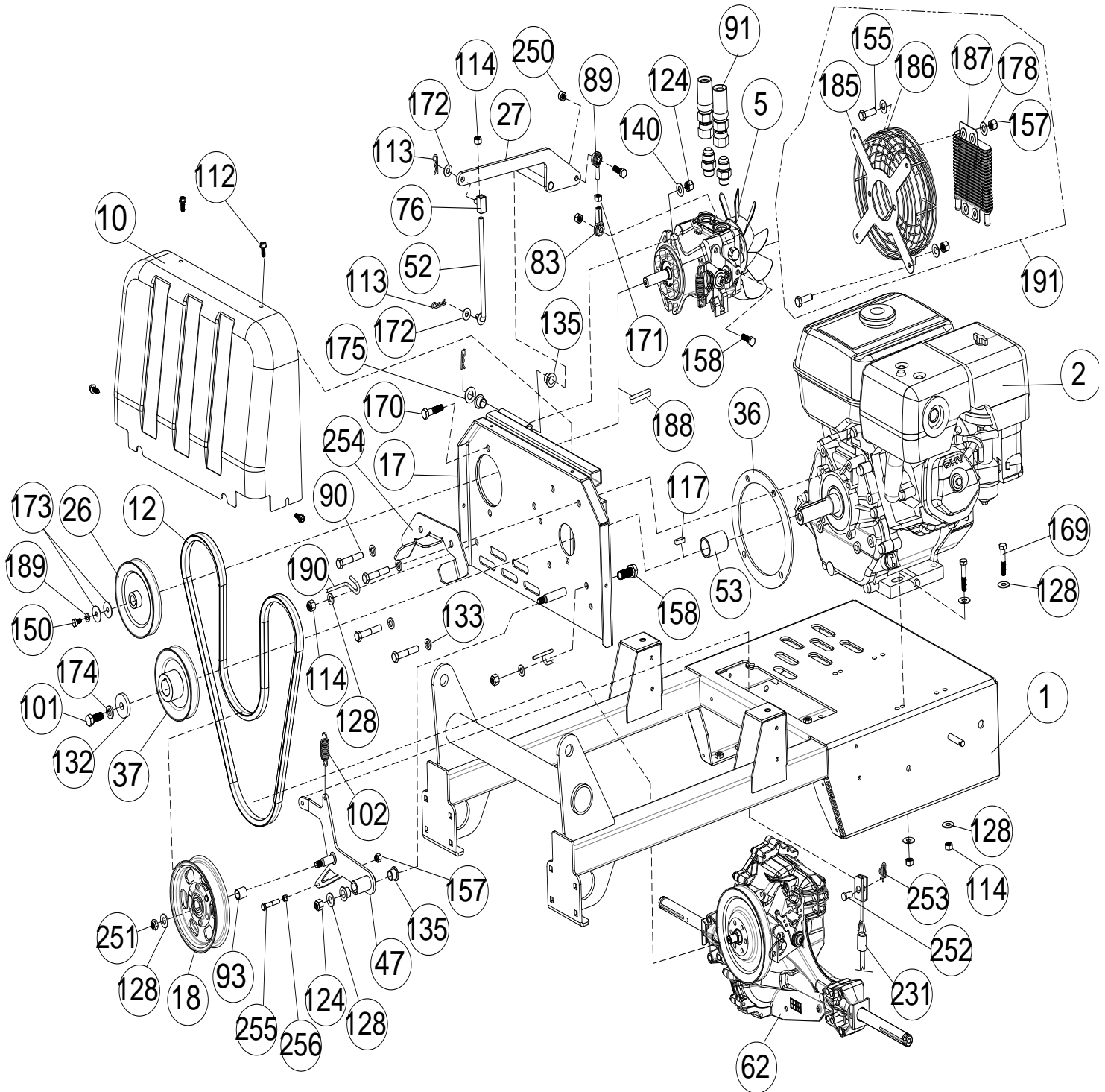



AE1300HEU Owner's Manual

AE1300HEU PARTS LIST ENGINE

Item No.	Part No.	Description	Qty
1	362602	ENGINE BASE WA	1
2	430366	ENGINE HONDA GX390 13 HP	1
5	362225	PUMP PK 12cc VARIABLE DISPLACEMENT	1
10	362327	GUARD BELT AE900	1
12	362337	BELT HP GP AMD EFF. LENGTH 64.04"	1
17	362111	PLATE PUMP MOUNT	1
18	362275	PULLEY 5.00" OD FLAT IDLER	1
26	362303	PULLEY 4.75 OD X .591 ID 5L	1
27	362116	ARM ENGAGE PUMP WA	1
36	440009	SPACER RING ENGINE	1
37	362391	PULLEY 4.50" OD X 1.00 ID 5L	1
47	362112	IDLER ARM WA AE900	1
52	362372	ROD PUMP ENGAGE	1
53	362406	SPACER ENGINE CRANKSHAFT	1
62	362332	TRANSAXLE AE900	1
76	362280	END ROD SLIDING	1
83	351278	SPHERICAL ROD END MSF-5	1
89	351277	SPHERICAL ROD END MSM-5	1
90	8041054	SCREWCAP 3/8"-16 X 2" HCS ZP	4
91	362279	HOSE HYDRAULIC W#10 JIC	2
93	362415	SPACER .75 OD X 11 GA	1
101	510213	SCREWCAP 7/16" - 20 X 1" HCS GR 8 W/PATCH	1
102	800242	SPRING EXTENSION	1
112	890359	SCREW SELF TAP 1/4"-20 X 5/8" HWH TYPE F	6
113	900471	PIN HAIR 1/4" ZP	3
114	8160002	NUT LOCK 5/16"-18 HEX ZP	9
117	9201113	KEY 1/4" SQ X 1.00"	1
124	8160003	NUT LOCK 3/8"-16	3
128	8171003	WASHER 5/16" FLAT ZP	12
132	440153	WASHER 1.5" OD X .453 ID X .25" THK	1
133	8177012	WASHER LOCK 3/8" S/T MED	4
135	362254	BUSHING .500" ID	4
140	8172009	WASHER 3/8" SAE	2
150	370128	SCREWCAP M6 X 14	1
155	8041004	SCREWCAP 1/4" - 20 X 3/4" GR 5 HCS ZP	8
157	8160001	NUT LOCK 1/4"-20 HEX ZP	9
158	8041028	SCREWCAP 5/16" - 18 X 1" GR 5 HCS ZP	4
169	8041031	SCREWCAP 5/16" - 18 X 1 3/4" GR 5 HCS ZP	4
170	8041052	SCREWCAP 3/8" - 16 X 1 1/2" HCS ZP	2
171	8142002	NUT 5/16"-18 HEX ZP	1
172	8171002	WASHER 1/4" FLAT ZP	6
173	8172019	WASHER FLAT FENDER 1/4"	2
174	8177013	WASHER LOCK 7/16" S/T MED	1
175	900230	WASHER 1/2" FLAT KD WHEEL MTG	1
178	8172007	WASHER 1/4" SAE	13
185	362330	BRACKET GUARD FAN	1
186	362331	GUARD WIRE PUMP FAN	1
187	362325	COOLER OIL	1
188	362380	KEY FEATHER 5MM X 5MM X 30MM	1
189	370120	WASHER SPLIT M6	2
190	370120	BELT FINGER AE900	2
191	362351	KIT FAN GUARD	1
231	362276	CABLE CLUTCH BELT AE900	1
250	8161041	NUT LOCK 5/16"-18 LT WT TH ZP	1
251	8161042	NUT LOCK 3/8"-16 LT WT TH ZP	1
252	440124	PIN CLEVIS 0.25 X 0.50	1
253	371275	1/4" RUE RING	1
254	862318	BRACKET BELT GUILD UPPER	1
255	8041010	SCREWCAP 1/4"-20 X 2" HCS ZP	1
256	900455	NUT WHIZ 1/4"-20 WASH FACE	1



AE1300HEU Owner's Manual

AE1300HEU PARTS DRAWING TINE

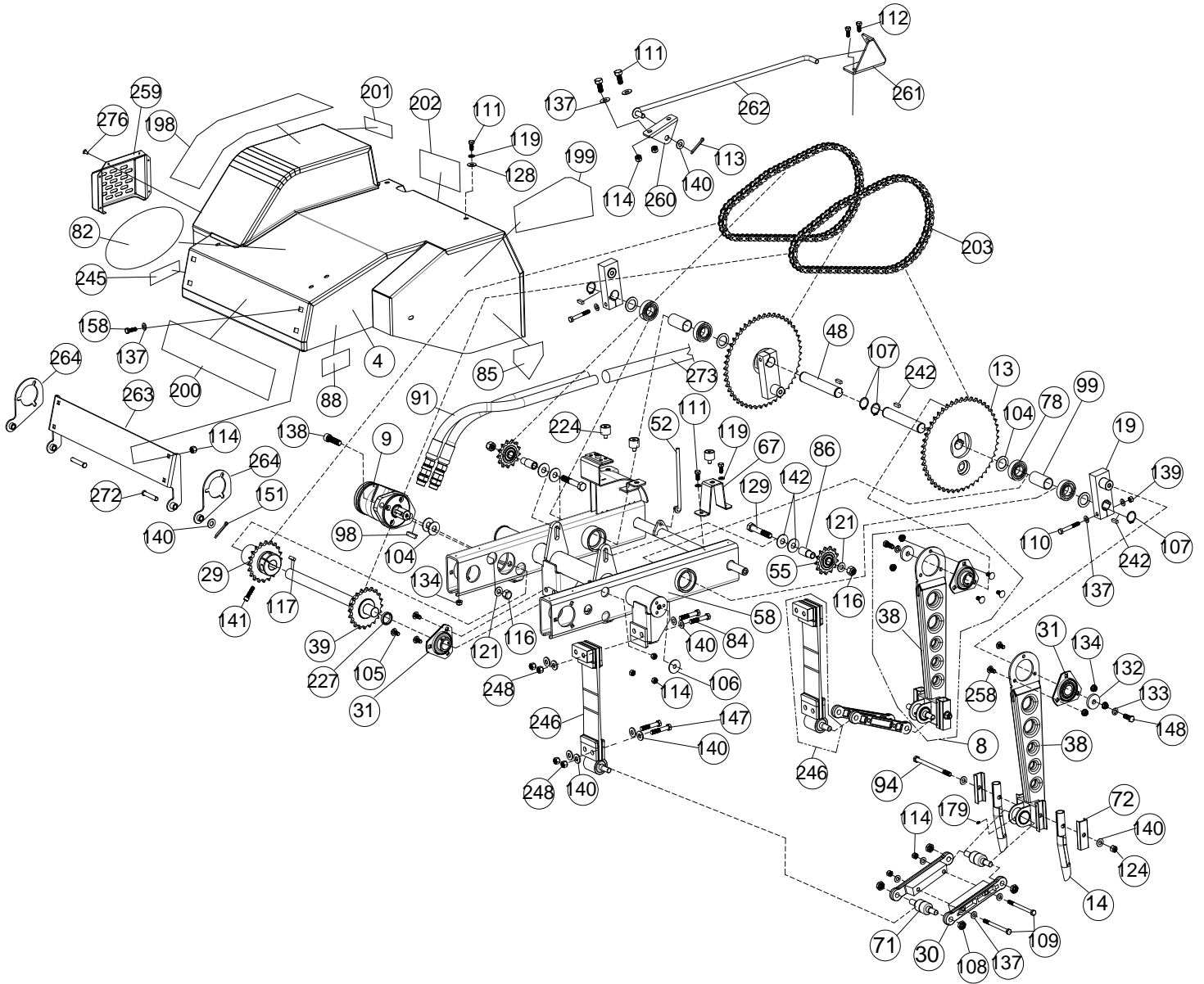



AE1300HEU Owner's Manual

AE1300HEU PARTS LIST TINE

Item No.	Part No.	Description	Qty	Item No.	Part No.	Description	Qty
4	362605	HOOD AE900	1	107	362212	RING RETAINING EXTERNAL 1.00"	4
8	362606	TINE ARM ASSY RIGHT AE900H SERVICE	2	108	610305	NUT LOCK 1/2" - 20 THIN	16
	362603	TINE ARM ASSY LEFT AE900H SERVICE	2	109	8041039	SCREWCAP 5/16"-18 X 4"" HCS ZP	8
9	362233	MOTOR TINE DRIVE	1	110	831272	SCREWCAP 5/16"- 24 X 2 1/4" GR 8 W/PATCH	4
13	362104	CRANK DRIVING WA AE900	2	111	8041026	SCREWCAP 5/16"-18 X 3/4" GR 5 HCS ZP	14
14	360100	TINE CORING 3/4	8	112	890359	SCREW SELF TAP 1/4"-20 X 5/8" HWH TYPE F	2
19	362103	ARM CRANK WA AE900	2	113	900471	PIN HAIR 1/4" ZP	1
29	362117	SPROCKET DRIVE AE900	1	114	8160002	NUT LOCK 5/16"-18 HEX ZP	17
30	362382	LINK CAST AE1300H	8	116	8160005	NUT LOCK 1/2"-13 HEX	4
31	362243	BEARING AND FLANGETTE ASSY 1.00	5	117	9201113	KEY 1/4" SQ X 1.00"	5
38	362102	TINE ARM WA AE900	1	119	8177011	WASHER LOCK 5/16" S/T MED	11
39	362105	SHAFT DRIVE TINE WA AE900	1	121	8172011	WASHER 1/2" SAE ZP	4
48	362227	SHAFT CRANK AE900	2	124	8160003	NUT LOCK 3/8"-16	4
52	362372	ROD PUMP ENGAGE	1	128	8171003	WASHER 5/16" FLAT	7
55	362261	SPROCKET 13T #50 IDLER	2	129	8041102	SCREWCAP 1/2"-13 X 3" HCS ZP	2
58	362101	FRAME TINE AE900	1	132	440153	WASHER 1.5" OD X .453 ID X .25" THK	4
67	362282	BRACKET REAR HOOD	1	133	8177012	WASHER LOCK 3/8" S/T MED	4
70	362281	BRACKET FRONT HOOD MOUNT	2	134	350346	NUT 5/16"-18 SER HEX FLNG ZP	18
71	362220	BEARING AND SHAFT	8	137	8172008	WASHER 5/16" SAE ZP	46
72	362407	HOLDER TINE AE900	16	138	362278	SHCS 1/2"-13 X 1.750" ZP	2
78	501302	BEARING 1" SEALED PRESS IN	2	139	8149002	NUT LOCK 5/16" - 24 FIN HEX ZP	4
82	430303	LABEL PRODUCT DECAL LG CIRCLE	1	140	8172009	WASHER 3/8" SAE	11
84	790167	SCREWCAP 3/8"-24 X 2 3/4" GR 8 W/PATCH	8	141	362289	SHCS 5/16"-18 X 1.25 BLK OX	1
85	400424	LABEL WARNING OPEI	2	142	8171006	WASHER 1/2" USS	4
86	360124	SPACER TINE IDLER 1.175"	2	147	810932	SCREWCAP 3/8"-24 X 2 1/4" GR 8 W/PATCH	8
88	900327	LABEL WARNING DANGER	2	148	900154	SCREWCAP 3/8" - 24 X 1" HCS GR 8	4
91	362279	HOSE HYDRAULIC W#10 JIC	2	151	8197031	PIN COTTER 1/8" X 1" ZP	2
94	362232	SCREWCAP 3/8"-16 X 5 3/4" GR 8	4	158	8041028	SCREWCAP 5/16" - 18 X 1" GR 5 HCS ZP	4
98	362288	KEY #15 HI PRO	1	198	362504	LABEL BADGING RISER	1
99	362246	SPACER SPINDLE BEARING AE900	2	199	362502	LABEL BADGING SIDE	2
104	362205	MACHINE BUSHING 1" X 1 1/2" X 14 GA	6	200	362503	LABEL BADGING FRONT	1
105	8024039	CARRIAGE BOLT 5/16" - 18 X 3/4" ZP	9	201	362506	LABEL WARNING HIGH PRESSURE	1
106	362284	WASHER ADHESIVE BACKED ISOLATION	7	202	362507	LABEL INSTRUCTION HYDRAULIC	1
				203	362258	CHAIN #50 X 70 PITCHES O-RING	2
				224	400173	VIBRATION MOUNT	5
				227	362416	SPACER 1.25 OD X 1.010 ID .258 LONG	1
				242	9201109	KEY 1/4" SQ X 0.75"	4
				243	362323	NUT LOCK 3/8"-24 HEX ZP	16
				245	100258	LABEL HOT SURFACE	1
				246	362607	SPRING ASSY AE900H	4
				248	362323	NUT LOCK 3/8"-24	16
				258	362224	BOLT CARRIAGE 5/16"-18 X 3/4" ZP SHRT NK	12
				259	362137	GUARD HYDRO MOTOR	1
				260	362394	HOOD GUIDE BRACKET UPPER	1
				261	362144	HOOD GUIDE BRACKET LOWER	1
				262	362393	HOOD LIFT ROD	1
				263	362143	HOOD BRACKET FRONT AEH	1
				264	362142	HOOD HINGE AEH	2
				272	381716	PIN CLEVIS 3/8" X 2" STAINLESS STEEL	2
				273	362430	SLEEVE HYDRAULIC LINE	2
				276	400978	RIVET 3/16" X 3/8	4



AE1300HEU PARTS DRAWING DRIVE

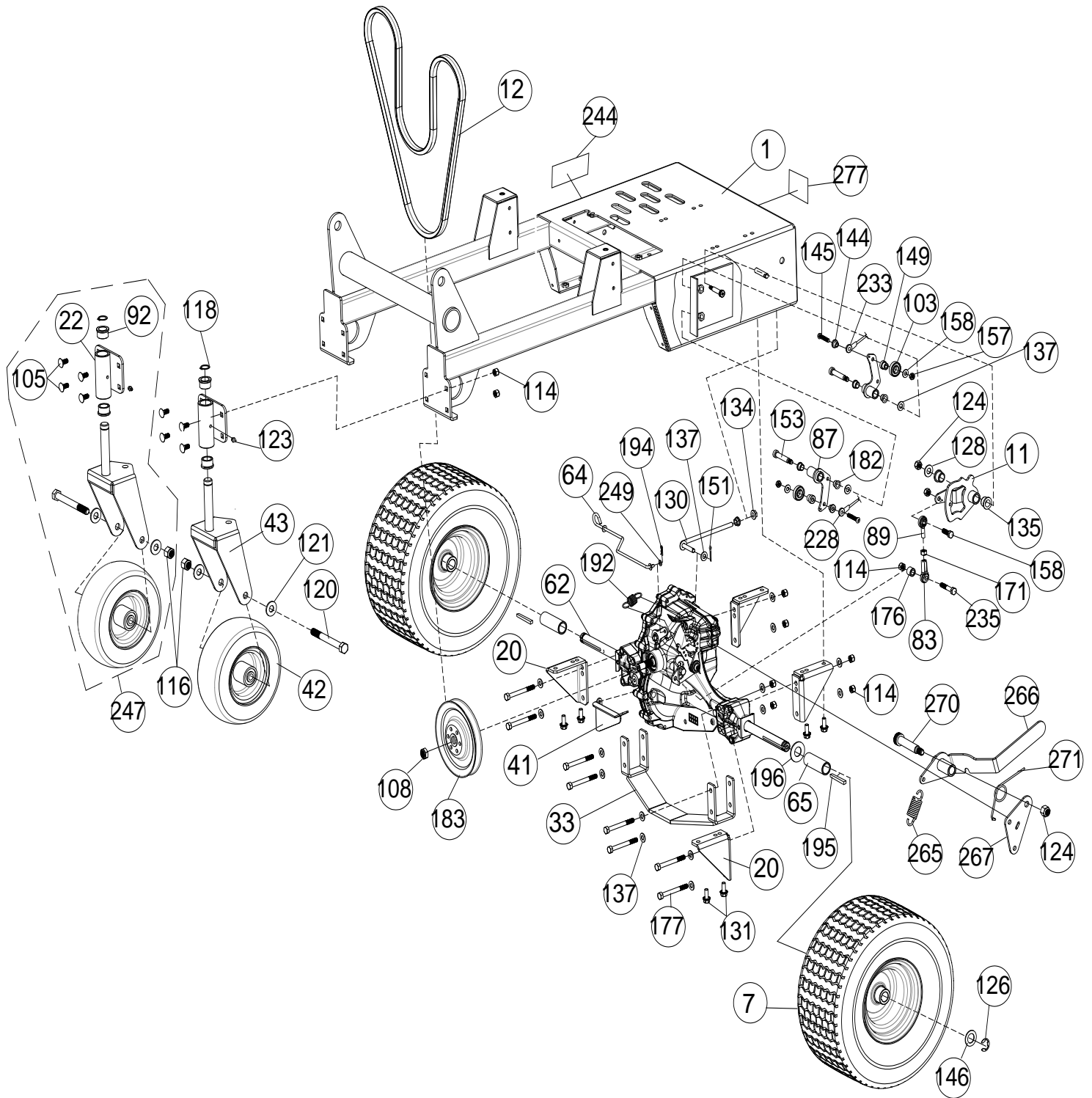



AE1300HEU Owner's Manual

AE1300HEU PARTS LIST DRIVE

Item No.	Part No.	Description	Qty
1	362100	ENGINE BASE WA	1
7	362352	WHEEL 15" X 6.00 - 6 TURF SAVER	2
11	362106	CAM SPEED CONTROL WA AE900	1
20	362329	BRACKET TRANSAXLE MOUNT	4
22	362107	BRACKET CASTER WA AE900	1
33	362118	SKID PLATE WA	1
41	362306	BRACKET BELT GUIDE LOWER AE900	1
42	371206	WHEEL 8" SOLID	2
43	371102	CASTER RIG WA SC	2
62	362332	TRANSAXLE AE900	1
64	362356	ROD BYPASS TRANSAXLE	1
65	362418	SPACER REAR WHEEL AE900H	2
83	351278	SPHERICAL ROD END MSF-5	1
87	501114	BELL CRANK BC2600 WA	2
89	351277	SPHERICAL ROD END MSM-5	1
92	520184	BUSHING FLANGE 1" OD 3/4" ID	4
103	351257	BEARING .500 ID X 1.125 OD X .313 THK	2
105	8024039	BOLT CARRIAGE 5/16" - 18 X 3/4" ZP	8
108	610305	NUT LOCK 1/2" - 20 THIN	1
114	8160002	NUT LOCK 5/16"-18 HEX ZP	18
116	8160005	NUT LOCK 1/2"-13 HEX	2
118	520176	RING RETAINING EXTERNAL 3/4"	2
120	8041108	SCREWCAP 1/2" -13 X 4 3/4" HCS ZP	2
121	8172011	WASHER 1/2" SAE	4
123	610363	ZERK GREASE FITTING	2
124	8160003	NUT LOCK 3/8"-16	5
126	850230	RETAINING RING E 3/4"	2
128	8171003	WASHER 5/16" FLAT	1
130	362341	ANTI ROTATION ROD	1
131	351264	SER HEX WSHR FLNG SCREW 5/16"-18 X 3/4"	8
134	350346	NUT 5/16"-18 SER HEX FLNG ZP	2
135	362254	BUSHING .500" ID	2
137	8172008	WASHER 5/16" SAE ZP	17
144	351348	SPACER SPEED CONTROL EYELET PM	2
145	8041008	SCREWCAP 1/4"-20 X 1 1/2" HCS ZP	2
146	850238	WASHER .765" ID X 1.25" OD X .06"	2
149	351347	SPACER SPEED CONTROL STEPPED PM	2
151	8197031	PIN COTTER 1/8" X 1" ZP	1
153	351258	BOLT SHOULDER 3/8" X 1 3/4"	2
157	8161040	NUT LOCK 1/4"-20 LT WT TH ZP	2
158	8041028	SCREWCAP 5/16" - 18 X 1" GR 5 HCS ZP	1
171	8142002	NUT 5/16"-24 HEX ZP	1
176	351419	SPACER ENGINE SIDE	1
177	8041036	SCREWCAP 5/16"-18 X 3" GR 5 HCS ZP	8
182	840078	BUSHING 3/8" ID X 1/2" OD X 3/8" LONG	4
183	362398	PULLEY DIA. 6.00 CUPPED 26 TOOTH SPLINE	1
192	351324	SPRING TRANSAXLE RETURN	1
194	440193	PIN CLIP HITCH 0.051 X 3/4"	1
195	9201092	KEY 3/16" SQ X 3.00	2
196	8172015	WASHER 3/4" SAE	2
235	8041030	SCREWCAP 5/16"-18 X 1 1/2" HCS ZP	2
244	501504	LABEL DRIVE RELEASE	1
247	362608	CASTER ASSY AE900H	2
249	8172005	WASHER #10 SAE	1
265	381157	SPRING EXTENSION 3/4" OD X 1"-3"	1
266	362146	PARKING BRAKE LEVER WA	1
267	362449	PARKING BRAKE BRACKET	1
270	520031	BOLT SHOULDER 1/2" X 2"	1
271	510142	SPRING TRANS IDLER	1
277	362511	LABEL PARKING BRAKE	1



AE1300HEU Owner's Manual

AE1300HEU PARTS DRAWING HANDLE

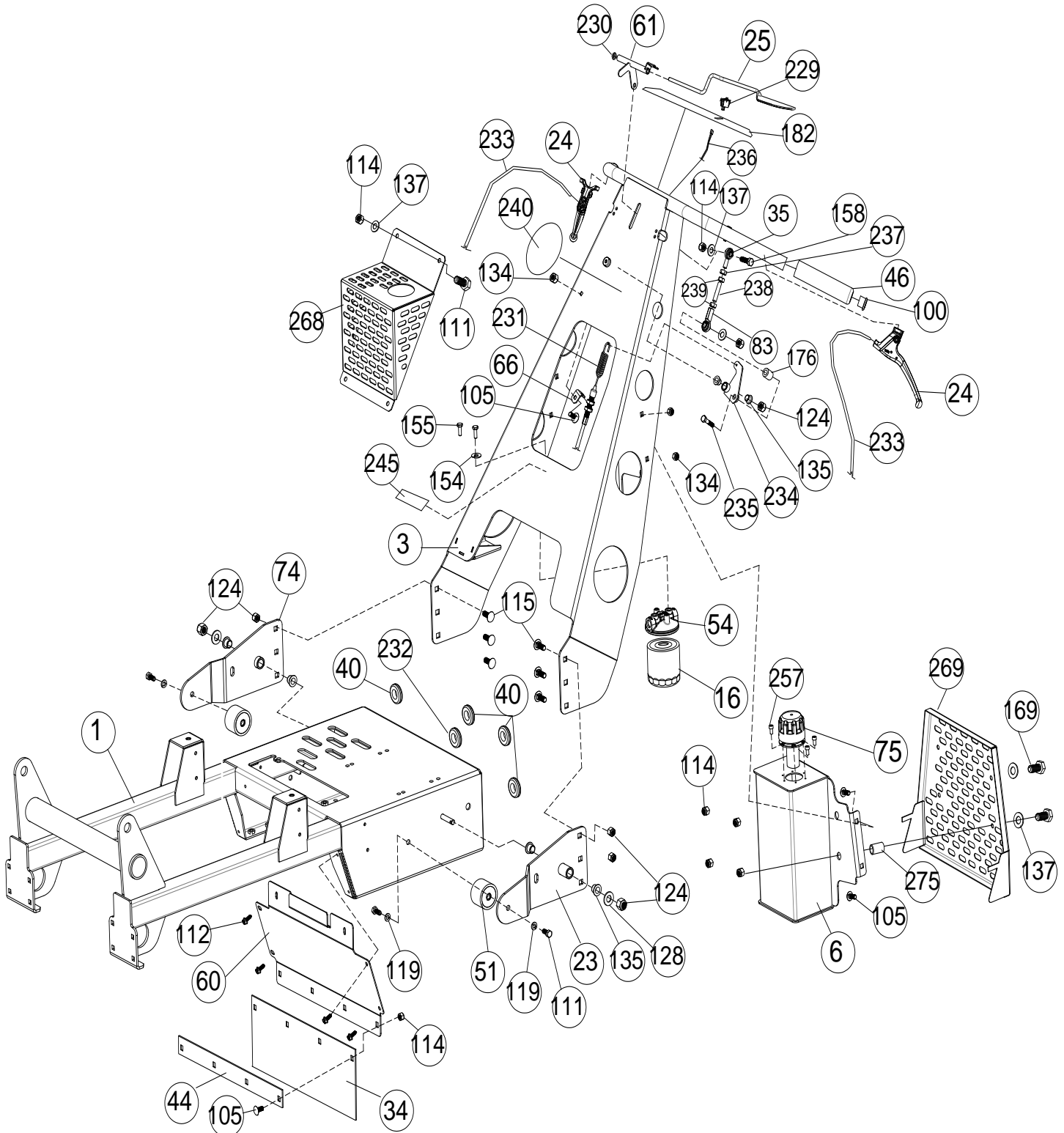



AE1300HEU Owner's Manual

AE1300HEU PARTS LIST HANDLE

Item No.	Part No.	Description	Qty
1	362602	ENGINE BASE WA	1
3	362604	HANDLE WA	1
6	362134	TANK OIL WA AE900H	1
16	362396	FILTER SPIN ON	1
23	362119	BRACKET LH HANDLE MOUNT WA	1
24	351209	MAGURA CONTROL	2
25	362267	BAIL ASSY AE900	1
34	351269	RUBBER DEFLECTOR	1
35	362269	SPHERICAL ROD END FEMALE 5/16"-24 LFT	1
40	520087	GROMMET 1" HOLE	4
44	351268	BAR CLAMP DEFLECTOR	1
46	500267	GRIP HANDLE 1" X 5.5"	2
51	371210	RUBBER HANDLE MOUNT	2
54	362395	MOUNT OIL FILTER	1
60	362292	GUARD TRANSAXLE FRONT	1
61	362129	BELL CRANK BAIL WA	1
66	351200	BRACKET CLUTCH CABLE OS900SP	1
74	362120	BRACKET RH HANDLE MOUNT WA	1
75	362342	RESERVOIR CAP	1
83	351278	SPHERICAL ROD END MSF-F	1
100	890132	PLUG TUBE INSERT 1" OD	2
105	8024039	CARRIAGE BOLT 5/16" - 18 X 3/4" ZP	9
111	8041048	SCREWCAP 3/8"-16 X 3/4" GR 5 HCS ZP	8
112	890359	SCREW SELF TAP 1/4"-20 X 5/8" HWH TYPE F	6
114	8160002	NUT LOCK 5/16"-18 HEX ZP	15
115	8024058	CARRIAGE BOLT 3/8"-16 X 1" ZP	6
119	8177011	WASHER LOCK 5/16" S/T MED	4
124	8160003	NUT LOCK 3/8"-16	8
128	8171003	WASHER 5/16" FLAT ZP	2
134	350346	NUT 5/16" -18 SER HEX FLNG ZP	5
135	362254	BUSHING .500" ID	4
137	8172008	WASHER 5/16" SAE ZP	10
154	8177010	WASHER LOCK 1/4" S/T MED	2
155	8041002	SCREWCAP 1/4" - 20 X 1/2" HCS ZP	2
158	8041028	SCREWCAP 5/16" -18 X 1" GR 5 HCS ZP	1
169	8041032	SCREWCAP 3/8"-16 X 1/2" HCS ZP	4
176	351419	SPACER ENGINE SIDE	1
182	362501	LABEL INSTRUCTION AE900H	1
229	362441	SWITCH ENGINE KILL TOGGLE	1
230	360218	NUT PAL 3/8"	1
231	362276	CABLE CLUTCH BELT AE	1
232	520092	GROMMET 1.25" HOLE	1
233	362312-S	CABLE SPEED CONTROL SERVICE	2
234	362121	BELLCRANK CABLE WA	1
235	8041030	SCREWCAP 5/16" - 18 X 1 1/2" GR 5 HCS ZP	1
236	362274	HARNESS WIRE KILL SWITCH	1
237	362322	NUT 5/16"-24 LEFT HAND FIN HEX ZP	1
238	362266	JACKSCREW 5/16"-24 RT AND LFT	1
239	8149002	NUT 5/16"-24 FIN HEX ZP	2
240	362505	LABEL INGROUND TURNING LOGO	1
245	100258	LABEL HOT SURFACE	1
257	8050057	SHCS 10-32 NF 1/2" SS	6
268	362145	TANK GUARD FRONT	1
269	362392	TANK GUARD REAR	1
275	362433	SPACER REAR GUARD AEH	4



AE1300HEU Owner's Manual

AE1300HEU PARTS DRAWING LIFT

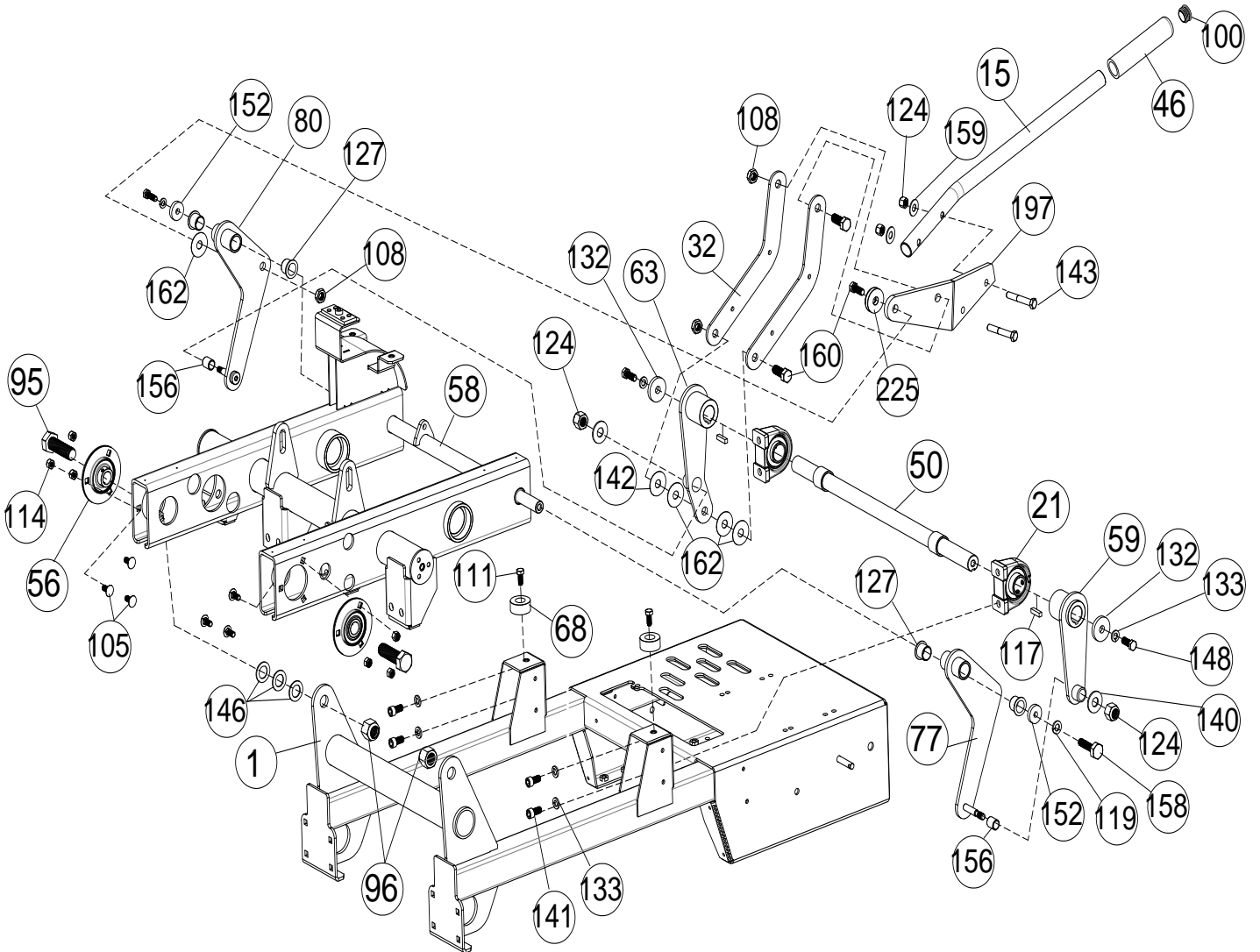



AE1300HEU Owner's Manual

AE1300HEU PARTS LIST LIFT

Item No.	Part No.	Description	Qty
1	362602	ENGINE BASE WA	1
15	362410	HANDLE TINE WA	1
21	362223	BEARING LIFT	2
32	362259	BRACKET HANDLE SUPPORT	2
46	500267	GRIP HANDLE 1" X 5.5"	1
50	362108	TINE FRAME LIFT SHAFT WA	1
56	362245	BEARING AND FLANGETTE ASSY .75"	2
58	362101	FRAME TINING AE900	1
59	362127	LIFT ARM LFT WA AE900	1
63	362125	ARM LIFT RT WA AE900	1
68	360298	BUMPER RECESS	2
77	362128	ARM TINE LIFT CONNECTING WA LH	1
80	362126	ARM TINE LIFT CONNECTING WA RH	1
95	8041166	SCREWCAP 3/4" - 10 X 2 1/2" LG ZP	2
96	8161006	NUT LOCK 3/4" - 10 ZP	2
100	890132	PLUG TUBE INSERT 1" OD	1
105	8024039	CARRIAGE BOLT 5/16" - 18 X 3/4" ZP	6
108	610305	NUT LOCK 1/2" - 20 THIN	3
111	8041026	SCREWCAP 5/16"-18 X 3/4" GR 5 HCS ZP	2
114	8160002	NUT LOCK 5/16"-18 HEX ZP	6
117	9201113	KEY 1/4" SQ X 1.00"	8
119	8177011	WASHER LOCK 5/16" S/T MED	2
124	8160003	NUT LOCK 3/8"-16	4
127	360183	BUSHING PIVOT FRAME AE	4
128	8171003	WASHER 5/16" FLAT ZP	2
132	440153	WASHER 1.5" OD X .453 ID X .25" THK	2
133	8177012	WASHER LOCK 3/8" S/T MED	6
140	8172009	WASHER 3/8" SAE	2
141	8049070	SHCS 5/16"-18 X 1.25 BLK OX	4
142	8171006	WASHER 1/2" USS	1
143	8041055	SCREWCAP 3/8" - 16 X 2 1/4" HCS ZP	2
146	850238	WASHER .765" ID X 1.25" OD X .06"	2
148	900154	SCREWCAP 3/8" - 24 X 1" HCS GR 8	2
152	441150	WASHER 1.125" OD X .344" ID X .25 THK	2
156	362257	BUSHING TINE FRAME PIVOT	2
158	8041028	SCREWCAP 5/16" - 18 X 1" GR 5 HCS ZP	2
159	8171004	WASHER 3/8" FC	2
160	520028	SCREWCAP 1/2" -20 X 1 1/4" GR 5 W/PATCH	3
162	362286	WASHER NYLON	6
197	362113	TINE ENGAGE HANDLE MOUNT WA	1
225	362419	WASHER 33/64 I.D. X 1.50" OD X .25 THK	1



AE1300HEU Owner's Manual

AE1300HEU PARTS DRAWING PUMP

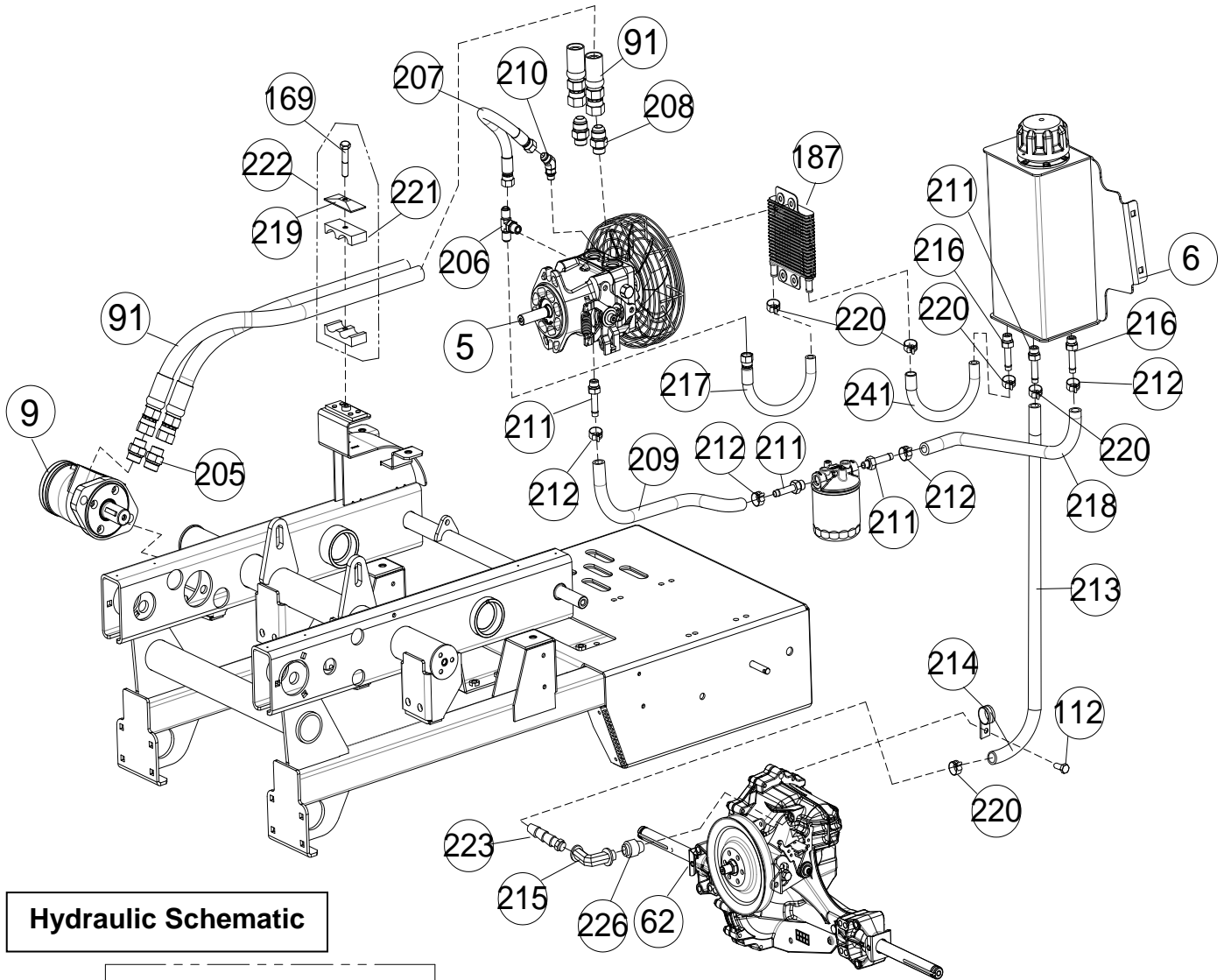

Hydraulic Schematic

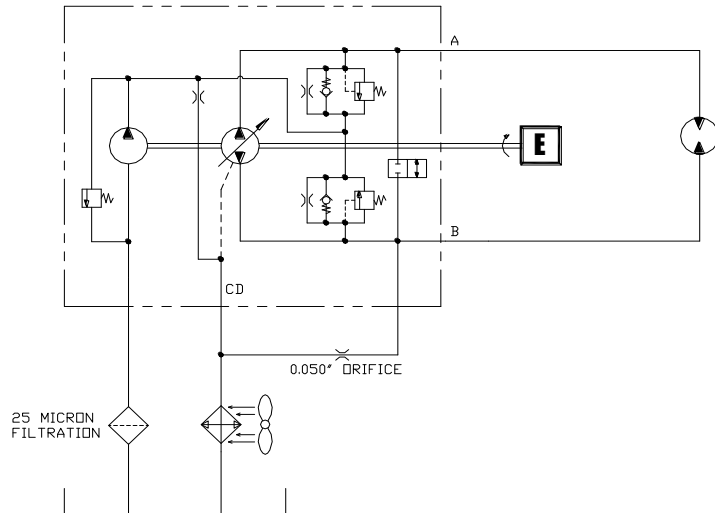



AE1300HEU Owner's Manual

AE1300HEU PARTS LIST PUMP

Item No.	Part No.	Description	Qty
5	362225	PUMP PK 12cc VARIABLE DISPLACEMENT	1
9	362233	MOTOR TINE DRIVE	1
91	362279	HOSE HYDRAULIC W#10 JIC	2
112	890359	SCREW SELF TAP 1/4" - 20 X 5/8" HWH TYPE F	1
169	8041032	SCREWCAP 3/8" - 16 X 1 2" HCS ZP	1
187	362325	COOLER OIL	1
205	362231	FITTING 10MJ - 10MOR STR	1
206	362420	FITTING TEE 6803-06-06-06	1
207	362423	HOSE ASSY #6 JIC TO RAW 11.00" LONG	1
208	362230	FITTING 10MF 0- 8MORB STRAIGHT	2
209	362426	HOSE HYDRAULIC 1/2" 12.00 LONG	1
210	362421	FITTING 45 DEG 6802-06-04 W/0.050" ORIFICE	1
211	362309	FITTING 08HB - 08MORB STRAIGHT	4
212	362311	CLAMP MINIATURE WORM GEAR MAH6	4
213	362425	HOSE HYDRAULIC 3/8" X 46.00" LONG	1
214	790170	HOSE CLAMP	1
215	362320	FITTING 90 DEG FEMALE TO FEMALE	1
216	362234	FITTING 06HB - 06MORB STRAIGHT	2
217	362422	HOSE ASSY #6 JIC TO RAW 13.00" LONG	1
218	362424	HOSE HYDRAULIC 3/8" X 22.00" LONG	1
219	362300	PLATE CLAMP COVER	1
220	362310	CLAMP MINIATURE WORM GEAR MAH4	4
221	362299	BODY PROFILED CLAMP	2
222	362013	HYDRAULIC HOSE CLAMP	1
223	362321	3/8" HOSE BARB	1
226	362315	04MORB - 02MP STRAIGHT	1
241	362427	HOSE HYDRAULIC 1/2" 18.00" LONG	1



AE1300HEU Owner's Manual



en	English	fi	Suomi	lv	Latviešu	ru	Русский
bg	Български език	fr	Français	nl	Nederlands	sl	Slovenščina
cs	Čeština	el	Ελληνικά	no	Norsk	sk	Slovák
da	Dansk	hr	Hrvatski	pl	Polski	sv	Svenska
de	Deutsch	hu	Magyar	pt	Português	tr	Türkçe
es	Español	it	Italiano	ro	Română		
et	eesti keel	lt	Lietuvių				

en	EC Declaration of Conformity	el	Δήλωση συμμόρφωσης EK	pl	Deklaracja zgodności UE
bg	Декларация за съответствие с европейските стандарти	hu	EU Megfelelőségi nyilatkozat	pt	Declaração de Conformidade à CE
cs	ES Prohlášení o shodě	hr	EC Deklaracija o skladnosti	ro	Declarație de conformitate C.E.
da	EC Overensstemmelseserklæring	it	Dichiarazione di conformità CE	ru	Заявление о соответствии стандартам и нормам EC
de	EG-Konformitätserklärung	lt	EB atitikties deklaracija	sl	ES izjava o skladnosti
es	Declaración de Conformidad de la CE	lv	EK Atbilstības deklarācija	sk	Vyhlasenie o zhode
et	Eü vastavustunnistus	nl	E.G. Conformiteitsverklaring	sv	EG-försäkran om överensstämmelse
fi	EC-vaatimustenmukaisuusvakuutus	no	CE konformitetserklæring	tr	EC Uygunluk Deklarasyonu
fr	Déclaration de conformité CE				

en	Category Aerator	el	Κατηγορία αεριστής	pl	Kategoria aerator
bg	Категория аератор	hu	Kategória áram	pt	Categoria aerador
cs	Kategorie perlátor	hr	Kategorija aerator	ro	Categorie aerator
da	Kategori belüfter	it	Categoria aeratore	ru	Категория аэратор
de	Kategorie Belüfter	lt	Kategorija aeratoriūs	sl	Kategorija aerator
es	Categoría aireador	lv	Kategorija aerators	sk	Kategória perlátor
et	Kategooria õhusti	nl	Categorie beluchter	sv	Kategori luftare
fi	Kategoria ilmastin	no	Kategori aerator	tr	Kategori havalandırıcı
fr	Catégorie aérateur				

en This is to certify that the products listed in this document meet the requirements of the European Community Law, and can carry the CE mark. These models comply with the following Directives and related Standards.

bg Декларацията се издава в удостоверение на това, че изброените продукти съответстват на стандартите на правните норми на Европейския съюз и могат да носят знака CE. Моделите изпълняват директивите и техните стандарти, както следва.

cs Tímto stvrzujeme, že výrobky uvedené v tomto dokladu splňují požadavky zákonů Evropského společenství a mohou být označeny značkou CE. Tyto modely splňují následující směrnice a související normy.

da Det bekræftes hermed, at de produkter, der er nævnt i dette dokument, opfylder bestemmelserne i EU-lovgivningen og kan bære CE-mærkatet. Disse modeller er i overensstemmelse med følgende direktiver og relaterede standarder:

de Hiermit wird bescheinigt, dass die in diesem Dokument aufgeführten Produkte mit den gesetzlichen Bestimmungen der Europäischen Gemeinschaft übereinstimmen und das CE-Zeichen tragen können. Diese Modelle erfüllen die folgenden Richtlinien sowie weitere anzuwendende Normen.

es La presente certifica que los productos enumerados en este documento cumplen con los requerimientos de la Legislación de la Comunidad Europea, y que pueden portar la marca CE. Estos modelos cumplen con las siguientes Directrices y Estándares relacionados:

et Kinnitame, et eespool nimetatud tooted vastavad Euroopa Ühenduse seadusandluse nõuetele ja kannavad CE-märgistust. Eespool nimetatud mudelid vastavad järgmistele direktiividele ja seotud standardidele:

fi Vakuutamme, että tässä asiakirjassa luetellut tuotteet täyttävät Euroopan Unionin lainsäädännön asettamat vaatimukset ja voi saada CE-merkinnän. Nämä mallit täyttävät seuraavien direktiivien ja niitä koskevien standardien vaatimukset:

fr Nous déclarons par la présente que les produits mentionnés dans le document sont conformes à la législation de la Communauté européenne et peuvent porter le marquage CE. Ces modèles sont conformes aux directives suivantes et aux normes connexes :

el Με την παρούσα δήλωση πιστοποιείται ότι τα προϊόντα που αναφέρονται στην παρούσα πληρούν τις απαιτήσεις της Ευρωπαϊκής Κοινωνικής Νομοθεσίας και μπορούν να φέρουν τη σήμανση CE. Τα μοντέλα αυτά συμμορφώνονται με τις ακόλουθες Οδηγίες και τα σχετικά Πρότυπα.

hu Ez annak tanúsítására szolgál, hogy a dokumentumban felsorolt termékek megfelelnek az Európai közösségi jog követelményeinek és viselheti a CE jelzést. Ezek a modellek eleget tesznek a következő irányelveknek és vonatkozó szabványoknak.

hr Ovo je potvrda da proizvodi koji su navedeni u ovom dokumentu odgovaraju zakonima europske zajednice i da nose CE oznaku. Ovi modeli zadovoljavaju sljedeće direktive i odgovarajuće standarde.

it Si certifica che i prodotti elencati nel presente documento soddisfanno i requisiti della legislazione della Comunità Europea e possono recare il marchio CE. Questi modelli sono conformi alle seguenti norme e direttive:

lt Šiuo patvirtiname kad šiame dokumente paminėti produktai atitinka Europos Bendrijos įstatymų reikalavimus ir jie gali būti pažymėti CE ženklu. Šie modeliai atitinka sekančias direktyvas ir standartus.

lv Ar šo tiek apstiprināts, ka šajā dokumentā uzskaitītie izstrādājumi atbilst Eiropas Kopienas Likuma prasībām un var tikt marķēti ar emblēmu CE. Šie modeļi atbilst sekojošajām Direktīvām un attiecīgajām Normām.

nl Hiermee wordt gecertificeerd dat de producten die in deze lijst staan opgesomd, voldoen aan de wettelijke voorschriften van de Europese Gemeenschap en mogen worden voorzien van de CE markering. Deze modellen voldoen aan de volgende richtlijnen en bijbehorende normen:

no Dette sertifiserer at produktene som er nevnt i dette dokumentet oppfyller kravene som stilles av EU, og at de dermed kan CE-merkes. Disse modellene tilfredsstiller følgende direktiver og relaterte standarder:

pl Niniejszym zaświadcza się, że produkty wymienione w niniejszym dokumencie spełniają wymogi Prawa Wspólnoty Europejskiej i mogą nosić oznakowanie CE. Modele te spełniają wymogi następujących dyrektyw i powiązanych norm.

pt O presente documento certifica que os produtos listados neste documento atendem aos requisitos das Leis da Comunidade Europeia e podem levar a marca CE. Esses modelos estão de acordo com as seguintes diretivas e padrões relacionados.

ro Prin prezenta se atestă faptul că produsele menționate în acest document îndeplinesc cerințele de Drept Comunitar European și pot purta sigla C.E. Aceste modele sunt în conformitate cu următoarele directive și standarde asociate.

ru Настоящим удостоверяется, что перечисленные в этом документе изделия соответствуют требованиям законов Европейского Союза и могут быть обозначены знаком CE. Эти модели отвечают требованиям следующих директив и соответствующих стандартов.

sl To služi kot potrditve, da izdelki, ki so navedeni v tem dokumentu, ustrezajo zahtevam zakonodaje Evropske skupnosti in so lahko opremljeni z oznako CE. Ti modeli so v skladu z naslednjimi direktivami in povezanimi standardi.

sk Týmto vyhlasujeme, že výrobky uvedené v tomto dokumente, splňajú požiadavky zákonov ES a môžu byť označené značkou CE. Tieto modely vyhovujú nasledujúcim smerniciam príslušným normám.

sv Härmed försäkras att produkterna som finns listade i detta dokument uppfyller kraven i Europeiska gemenskapens lagstiftning och kan förses med CE-märket. Modellerna uppfyller följande direktiv och tillhörande normer.

tr Bu belgede belirtilen ürünlerin Avrupa Birliği Yasası gereksinimlerini karşılayarak CE işareti taşıyabilmesini onaylamak içindir. Bu modeller aşağıdaki Direktif ve ilgili Standartlarla uyumludur



AE1300HEU Owner's Manual

en Directive: 2006/42/EC	hu Irányelv: 2006/42/EC	pt Directiva: 2006/42/EC
bg Директива: 2006/42/EC	el Οδηγία: 2006/42/EC	ru Директива: 2006/42/EC
cs Směrnice č. 2006/42/EC	hr Direktiva: 2006/42/EC	ro Directiva: 2006/42/EC
da Direktiv: 2006/42/EF	it Direttiva: 2006/42/EF	sl Direktiva: 2006/42/EF
de Richtlinie: 2006/42/EG	lt Direktyva: 2006/42/EG	sk Smernica: 2006/42/EG
es Directriz: 2006/42/EC	lv Direktīva: 2006/42/EC	sv Direktiv: 2006/42/EC
et Direktiiviga: 2006/42/EÜ	nl Richtlijn: 2006/42/EÜ	tr Direktif: 2006/42/EÜ
fi Direktiivi: 2006/42/EC	no Direktiv: 2006/42/EC	
fr Directives : 2006/42/CE	pl Dyrektywy: 2006/42/CE	

en Model	Guaranteed Sound Power Level	Measured Sound Power Level	Sound Pressure Level at Operator's Ear (1)	Engine Net Power	Hand/Arm Vibration (2)	Mass
bg Модел	Гарантирано ниво на звука	Измерено ниво на звука	Налигане на звука, измерено на нивото на ухото на оператора (1)	Мощност на двигателя	Вибрация на дланта и на ръката (2)	Маса
cs Model	Garantovaná hladina akustického výkonu	Změřená hladina akustického výkonu	Hladina akustického tlaku naměřená u ucha obsluhující osoby (1)	Užitečný výkon motoru	Vibrace rukou/paří (2)	Váha
da Model	Garanteret støjniveau	Målt støjniveau	Lydtrykkniveau ved brugerens øre (1)	Maskine Netto kraft	Vibration af hånd/arm (2)	Vægt
de Modell	Garantierter Schalleistungspegel	Gemessener Schalleistungspegel	Schalldruckpegel am Ohr der Bedienungsperson (1)	Motornettleistung	Vibrationen an Hand/Arm (2)	Masse
es Modelo	Nivel garantizado de potencia acústica	Nivel medido de potencia acústica	Nivel de presión acústica en el oído del operador (1)	Potencia neta del motor	Vibración mano / brazo (2)	Masa
et Mudel	Garanteeritud helivõimsuse tase	Mõõdetud helivõimsuse tase	Helirõhu tase kasutaja kõrvna juures (1)	Masin puhas töötab	Võkumine käsi / käsivars (2)	Massi
fi Malli	Taattu äänitehotaso	Mitattu äänitehotaso	Äänenpaine taseo käyttäjän korvan tasolla (1)	Moottorin nettoteho	Käden/käsivarren värinä (2)	Paino
fr Modèle	Niveau de bruit garanti	Niveau de bruit mesuré	Niveau sonore au niveau de l'oreille de l'opérateur (1)	Puissance nette du moteur	Vibrations au niveau de la main/du bras (2)	Masse
el Μοντέλο	Εγγυημένη στάθμη ηχητικής ισχύος	Μετρηθείσα στάθμη ηχητικής ισχύος	Στάθμη ηχητικής πίεσης στο αυτί του χειριστή (1)	Καθαρή ισχύς κινητήρα	Χειροβραχιονική δόνηση (2)	Μάζα
hu Model	Garantált hangteljesítmény szint	Mért hangteljesítmény szint	Hangnyomás szint a gépkezelő fülénél (1)	Motor hasznos teljesítménye	Kéz/kar vibráció (2)	Tömeg
hr Model	Zajamčena razina snage zvuka	Izmjerena razina snage zvuka	Razina zvučnog tlaka na uhu rukovatelja (1)	Neto snaga motora	Vibracije šake/ruke (2)	Masa
it Modello	Livello acustico garantito	Livello acustico misurato	Livello di pressione acustica all'orecchio dell'operatore (1)	Potenza netta motore	Vibrazioni a mani/braccia (2)	Massa
lt Modelis	Garantuotas triukšmo lygis	Pamatuotas triukšmo lygis	Garso spaudimo lygis įrangos naudotojui (1)	Variklio bendras galingumas	Rankenos vibracija (2)	Masė
lv Modelis	Garantētais skaņas jaudas līmenis	Izmērītais skaņas jaudas līmenis	Skaņas spiediena līmenis pie operatora auss (1)	Dzinēja neto jauda	Rokas/pleca vibrācija (2)	Masa
nl Model	Gegarandeerd geluidsdrukniveau	Gemeten geluidsdrukniveau	Geluidsdrukniveau bij het oor van de gebruiker (1)	Netto motorvermogen	Trilling van hand/arm (2)	Mass
no Modell	Garantert lydstyrkenivå	Målt lydstyrkenivå	Lydtrykk-nivå ved operatørens øre (1)	Motorens netto krefter	Hånd/arm-vibrasjon (2)	Masse
pl Model	Gwarantowany poziom mocy akustycznej	Zmierzony poziom mocy akustycznej	Poziom ciśnienia akustycznego w uchu operatora (1)	Moc netto silnika	Drgania ręki/ramienia (2)	Masa
pt Modelo	Nível de potência de som garantido	Nível de potência de som medido	Níveis de pressão do som no ouvido do operador (1)	Potência útil do motor	Vibração na mão/braço (2)	Massa
ro Model	Nivel de zgomot garantat	Nivel de zgomot măsurat	Nivel de presiune acustică la urechea operatorului (1)	Putere netă a motor	Vibrație mână/braț (2)	Masă
ru Модель	Гарантированный уровень звуковой мощности	Измеренный уровень звуковой мощности	Уровень звукового давления на месте оператора (1)	Полезная мощность двигателя	Интенсивность вибрации на ладонях/руках (2)	Вес
sl Model	Zajamčena raven zvočne moči	Izmerjena raven zvočne moči	Raven zvočnega tlaka pri užesu uporabnika (1)	Izhodna moč motorja	Tresljaji na rokah (2)	Masa
sk Model	Zaručená hladina akustického výkonu	Nameraná hladina akustického výkonu	Hladina akustického tlaku pôsobiaceho na ucho obsluhy (1)	čistý výkon motora	Ruka/Rameno Vibrácia (2)	Masa
sv Modell	Garanterad ljudeffektivitet	Uppmått ljudeffektivitet	Ljudtrykknivå vid operatörens öra (1)	Motoreffekt netto	Hand-/ armvibrationer (2)	Massa
tr Model	Garantili Ses Gücü Seviyesi	Ölçülen Ses Gücü Seviyesi	Operatörün Kulakındaki Ses Basıncı Seviyesi (1)	Makine Net Gücü	El/Kol Titreşimi (2)	Ağırlık
AE1300HEU	104 dB(A)	103 dB(A)	83 dB(A)	9.7 kW	6.67 m/s ²	240 kg

(1) ISO 5395-1:2013 F.7 (EN 4871:1996)
(2) ISO 5395-1:2013 G.8 (EN 12096:1997, D.1)



AE1300HEU Owner's Manual

en	Manufacturing Place / Keeper of Documentation	el	Τόπος κατασκευής / Υπεύθυνος τήρησης αρχείων τεκμηρίωσης	pl	Miejsce produkcji / Osoba odpowiedzialna za przechowywanie dokumentów
bg	Място на производство / Архивар	hu	Gyártás helye / A dokumentáció őrzője	pt	Local de fabrico / Responsável pela Documentação
cs	Místo výroby / Držitel dokumentace	hr	Mjesto proizvodnje / Čuvar dokumentacije	ro	Loc de fabricație / Păstrător documentație
da	Fremstillingssted / Indehaver af dokumentationen	it	Sede di produzione / Archiviare di documentazione	ru	Место производства / Владелец документации
de	Herstellungsort / Verantwortlicher für die Dokumentation	lt	Pagaminių vieta / Dokumentacijos turėtojas	sl	Kraj izdelave / Hranitelj dokumentacije
es	Lugar de manufactura / Guardián de documentación	lv	Ražošanas vieta / Dokumentācijas glabātājs	sk	Miesto výroby / Dokumentácia majiteľa
et	Valmistamiskoht / Dokumentatsiooni hoidja	nl	Productieplaats / Documentatiebeheerder	sv	Tillverkningsplats / Dokumentförvaring
fi	Valmistuspaikka / Asiakirjojen haltija	no	Produksjonssted / Dokumentasjonsholder	tr	Üretim Yeri / Doküman Sorumlusu
fr	Lieu de fabrication / Personne chargée de conserver la documentation				

1803 S.W. Jefferson
Lees Summit, MO 64063-
0308 USA

Jeroen Engelen
Schepersweg 4a 6049CV
Herten, NL

Ted Melin
Engineering Manager

Part No. 362513
Revision: F100515A

10/05/2015